

MAJESTIC  
**INSTALLATION GUIDE**  
-  
**HARMONY ALCOVE**

01279 443644  
**INFO@MAJESTICSHOWERS.COM**  
-  
**MAJESTICSHOWERS.COM**

**MAJESTIC**

**LONDON 1968**

**Harmony Alcove Installation Guide**

vSEP16

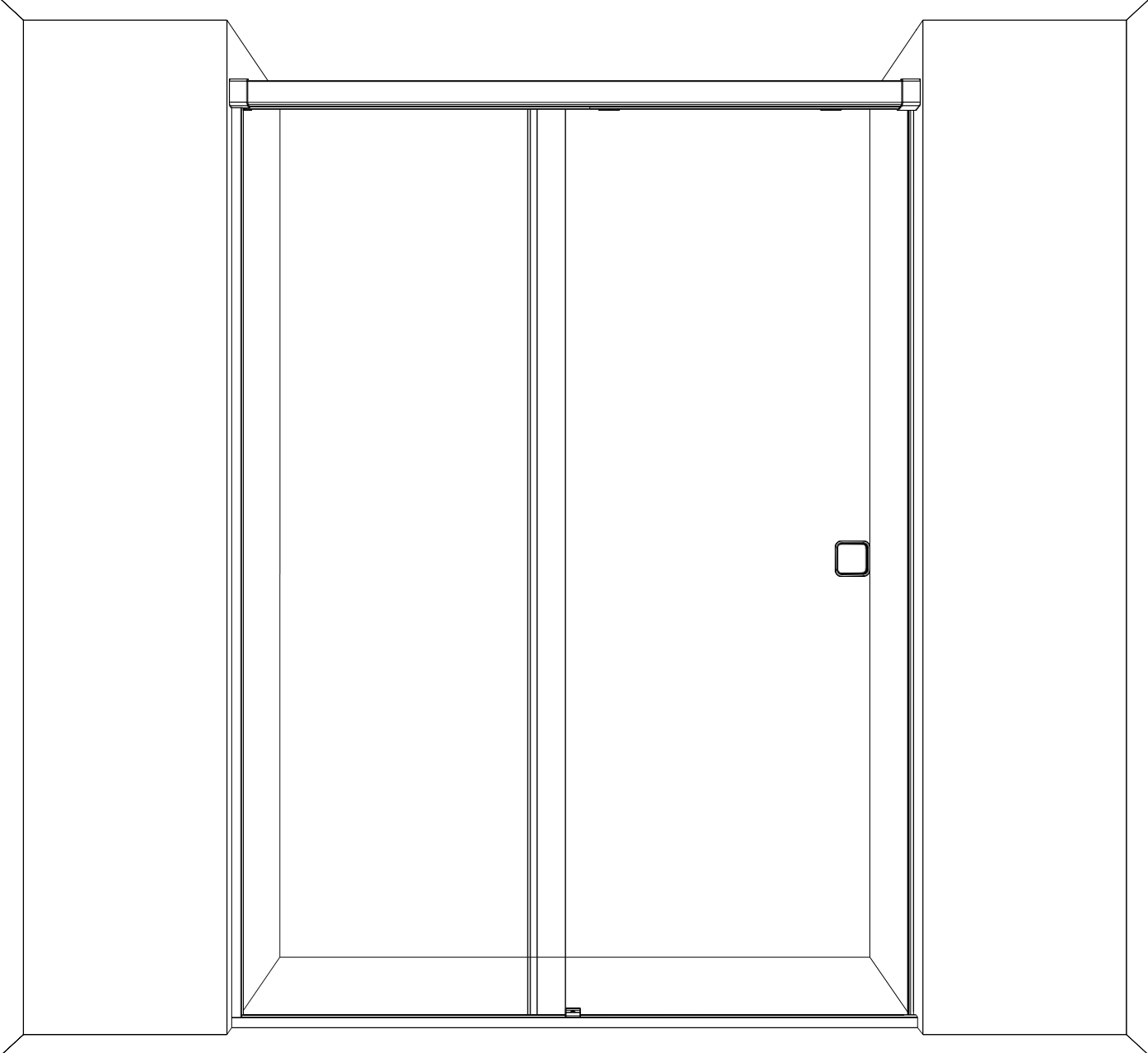

Thank you for purchasing this Harmony Alcove shower screen. Please study these instructions carefully before assembly and installation and check all supplied parts immediately upon receipt.

These instructions illustrate an enclosure with the door on the right and a fixed panel on the left. However, all parts are reversible and the door may optionally be positioned to the left of the fixed panel.

Harmony Alcove screens can be installed up to a maximum height of 2.3 metres and as close as 15mm from the top of the rail to finished ceiling level.

Please consult the Majestic Shower Company if you require information on bespoke options.

## Pre Installation Checks

Prior to undertaking installation, check the accuracy of the following against specifications for the particular installation location:

- finished wall to finished wall at floor level and at 2 metres above floor level
- verticality of walls.
- floor flatness and levelness (or tray rim flatness and levelness if a shower tray is used).

Width dimensions should be within 5-6mm. Some lean-in or lean-out is acceptable on the panel side wall (up to 5-6mm) but the door side wall has to be very close to vertical to ensure adequate sealing of the door either on to the wall surface or into the wall channel (2-3mm maximum deviation).

## Parts Supplied

The following parts are supplied. Please check them and contact the Majestic Shower Company in the event of missing or damaged parts.

Note that the components supplied for the Door Stop in the Rail are slightly different for smaller units than for larger. Standard units 1100mm and 1200mm wide and bespoke units less than 1230mm wide have a fixed position soft stop cylinder housed in a Cover Block at the end of the Rail whereas wider units have a cylinder in a variable position housing.

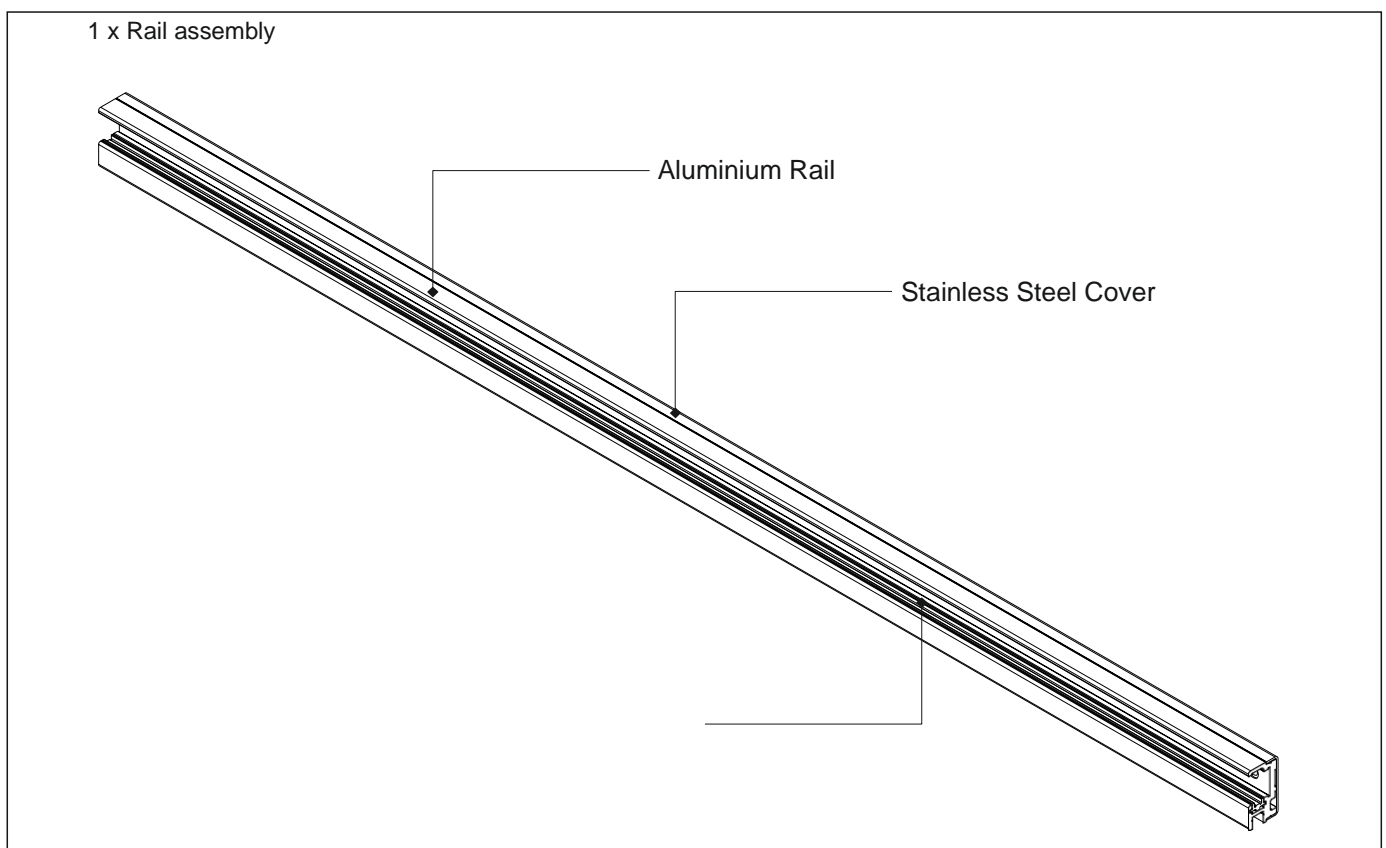

1 x Wall Bracket for Panel end of Rail  
(either left hand or right hand) with fixings

Left Hand OR Right Hand

1 x 1 x 2 x 3 x

1 x Wall Bracket for Door end of Rail  
(either left hand or right hand) with fixings

Left Hand OR Right Hand

1 x 1 x 2 x 3 x

2 x Wall plates with wall  
plugs and screws

2 x 2 x

**FOR UNITS GREATER THAN 1230mm WIDE**

2 x Cover Blocks with fixings

1 x Door Stop assembly including  
Softstop cylinder

2 x 2 x

1 x Glass In-line Panel

**FOR UNITS 1230mm OR LESS WIDE**

1 x Cover Block for Door end  
of Rail, with fixings.

1 x Cover Block incorporating  
Softclose cylinder for Panel  
end of Rail, with fixing.

2 x 2 x

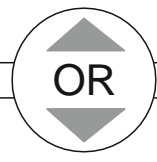

1 x Underframe extrusion

1 x 17mm Surface Profile

1 x Infill Profile for Rail

1 x Infill Profile for Underframe

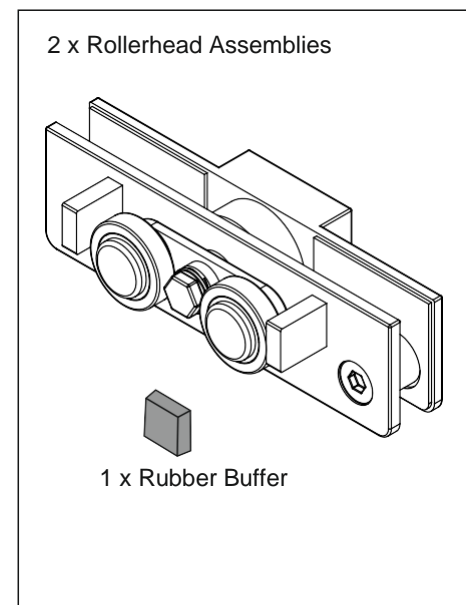
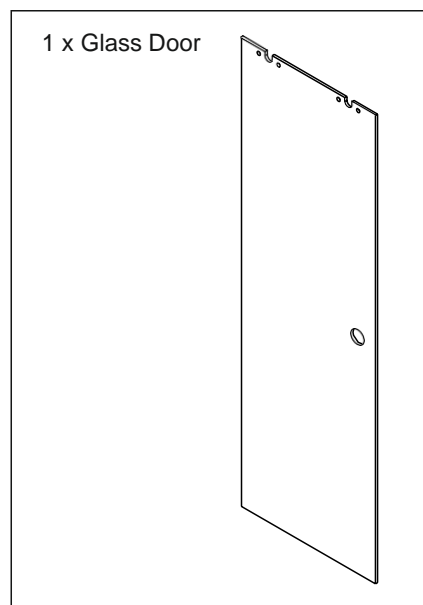
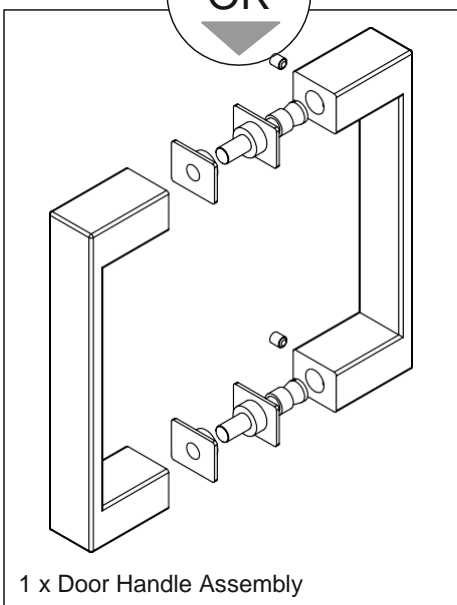
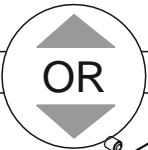
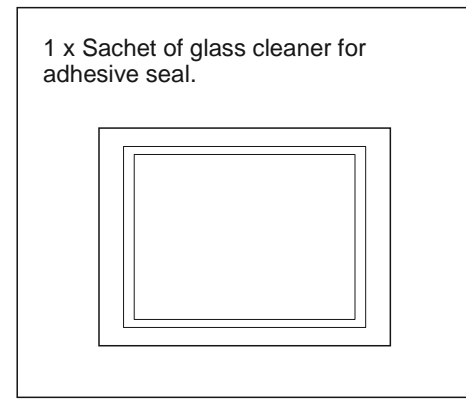
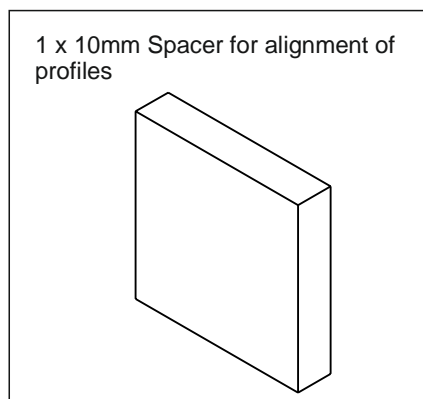
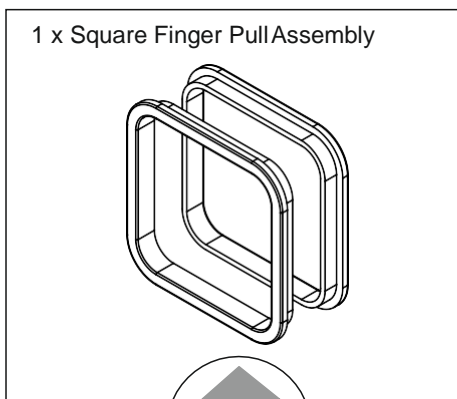
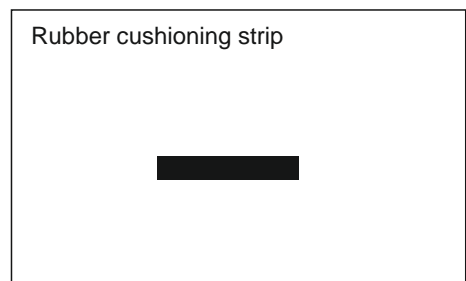
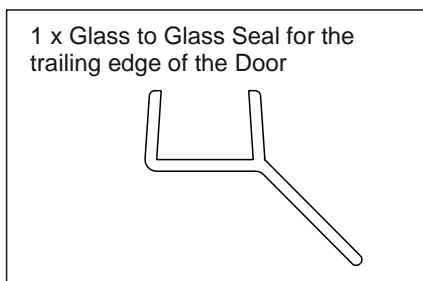
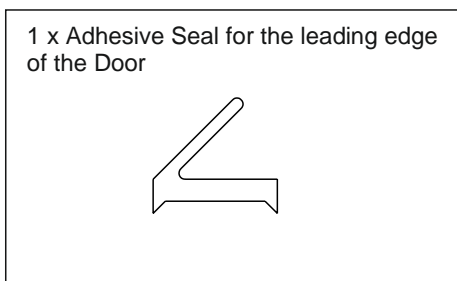
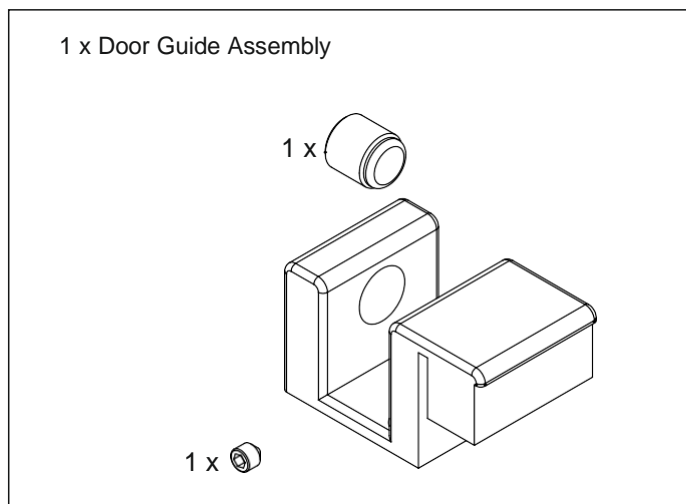
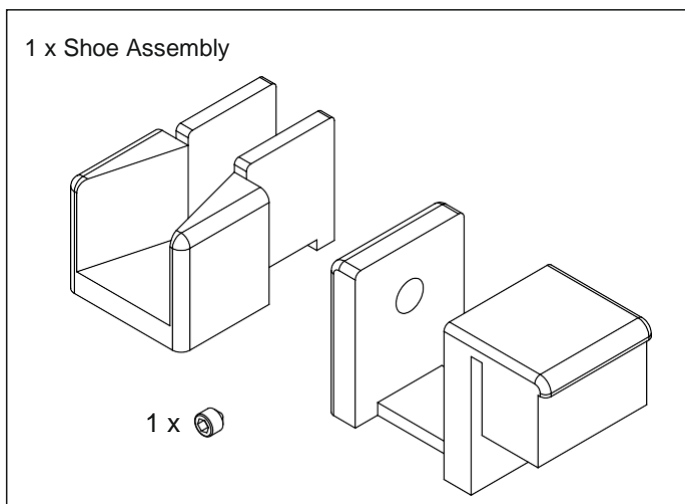

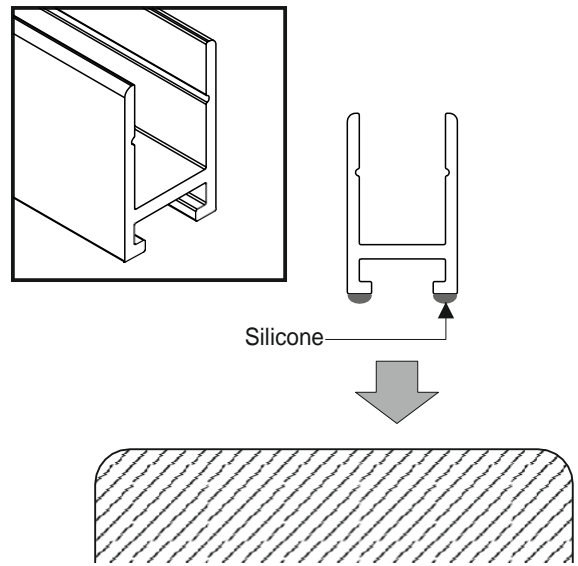
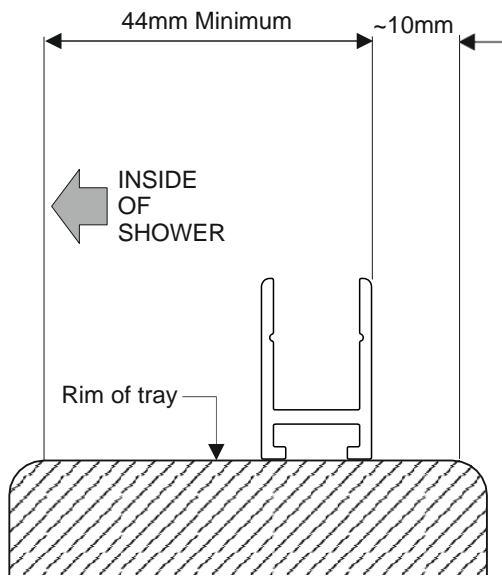

**1** Cut the underframe to the exact width of the alcove and place it in position.

If a shower tray is used, ensure that there is at least 44mm of flat rim behind the front edge of the underframe to leave space for the floor guide. Ideally, the front of the underframe should be about 10mm back from the front of the tray. Mark the position.

**2** Apply beads of silicone to the bottom of the underframe as shown and apply a small amount to each end where the underframe will sit against the wall.

Tape the underframe in position whilst the silicone sets.

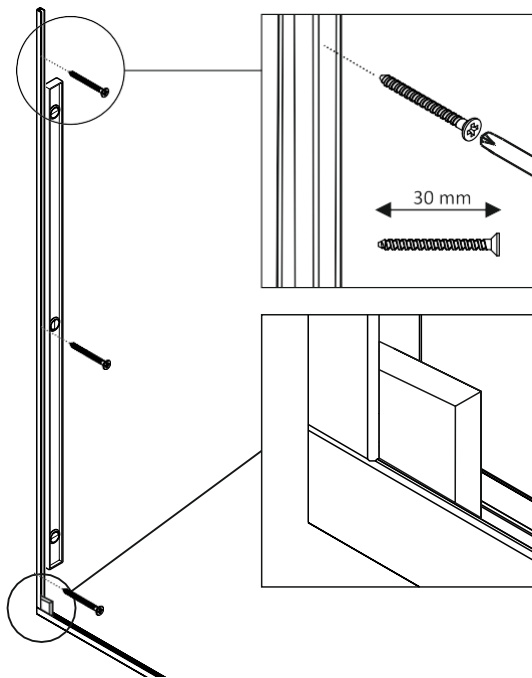

**3** Place the 17mm Surface Profile in position at the panel end of the underframe, using a long spirit level to ensure that it is vertical and using the 10mm spacer block to ensure alignment with the underframe at the bottom. Mark the screw hole positions.

Remove the Surface Profile, drill the wall, fit the wall plugs and then screw the Profile back in position.

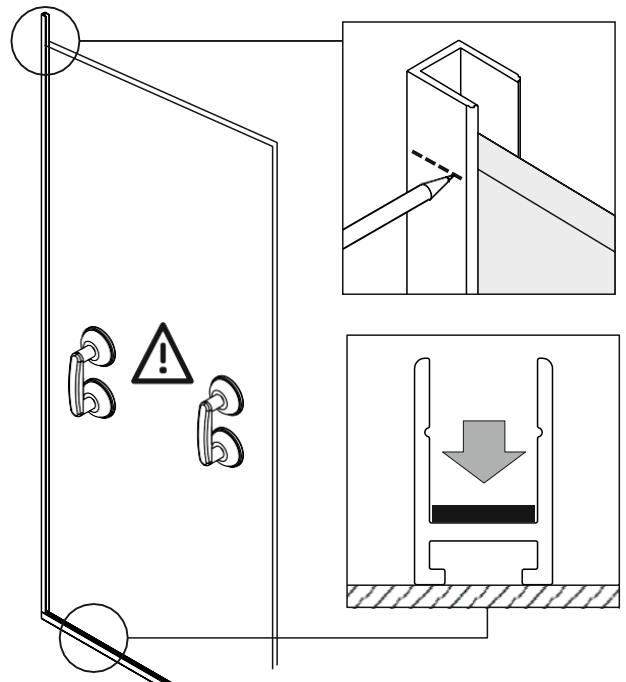

**4** Lay a strip of rubber inside the underframe to cushion the glass and then, using glass lifters, place the glass panel in position.

Check that the top edge is perfectly horizontal, adding more rubber strip packing underneath if necessary.

Mark the Surface Profile at the top edge of the glass.

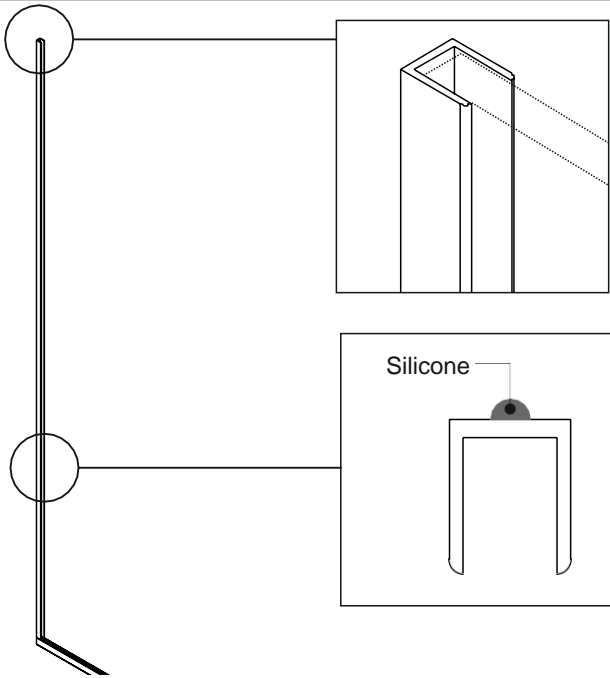

**5** Remove the glass. Remove the 17mm Surface Profile and cut to length so that it will be level with the top of the glass.

Run a bead of silicone along the back of the Surface Profile and screw it back in position.

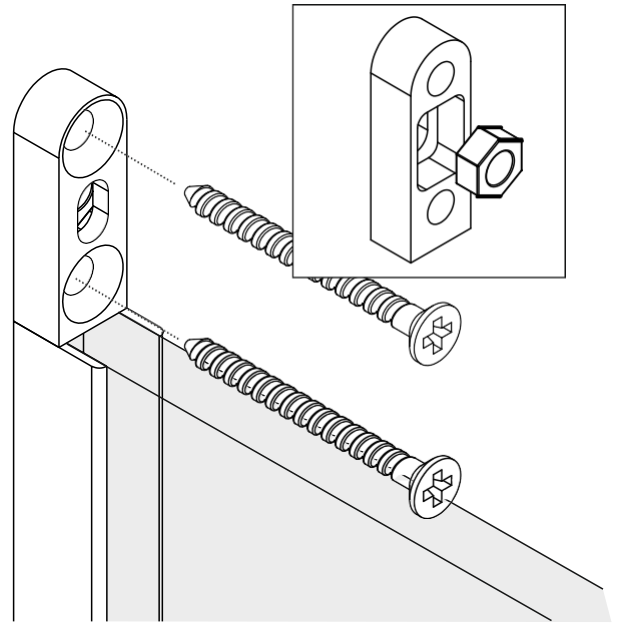

**6** Place the M6 nuts in the recess in the back of each wall plate using a smear of silicone to hold them in position at the top of the recess during assembly.

Screw one wall plate at the top of the wall channel as shown. Fix the other in an identical position on the door side wall. Use a straight edge against the top edge and face of the glass panel to determine this position.

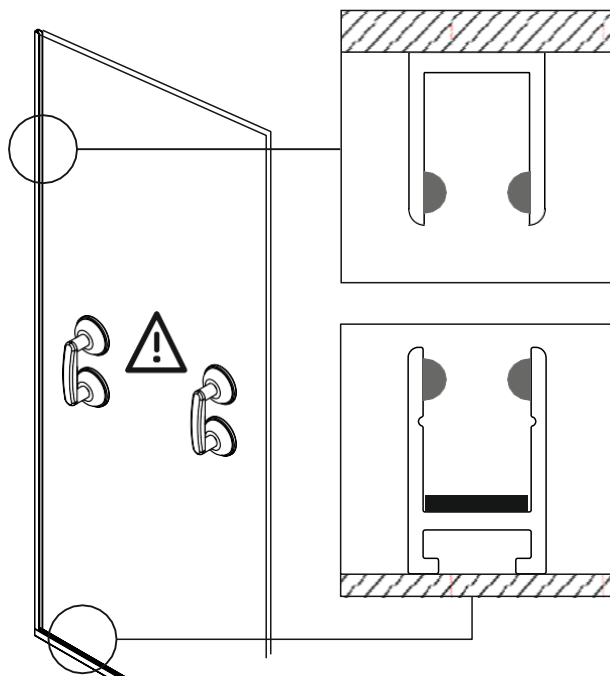

**7** Apply a continuous bead of silicone to both inside faces of the underframe and the Surface Profile as shown and lift the glass panel back into position.

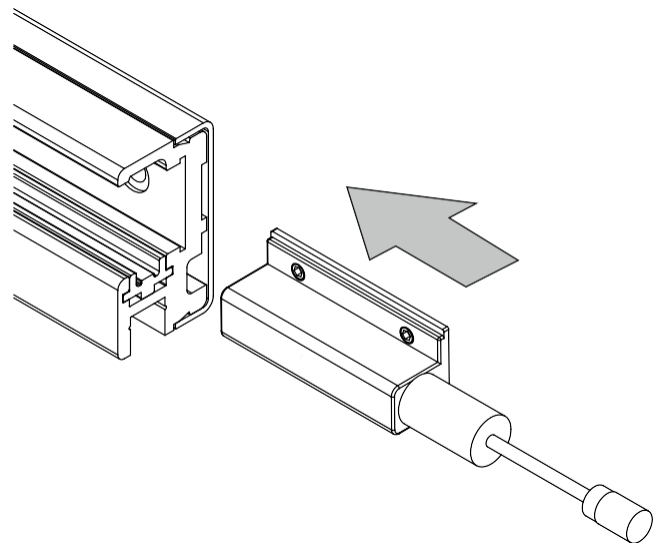

**8** **FOR UNITS 1320mm OR WIDER ONLY**

Fit the Soft Stop cylinder into its housing with a light smear of silicone to retain it. Note that the cylinder is to be facing towards the Door.

Slide the door stop assembly in to the Rail extrusion as shown. Do not tighten screws - leave it to move freely at this stage.

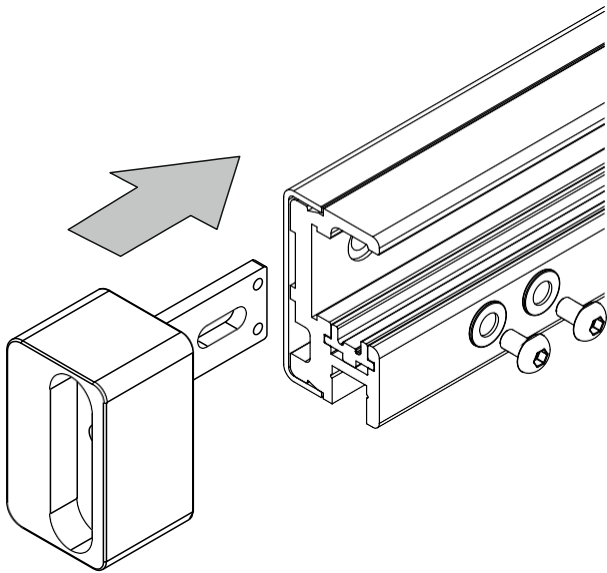

9

Assemble the Wall Bracket to the door end of the Rail using 2 pan head screws and washers. Do not tighten yet.

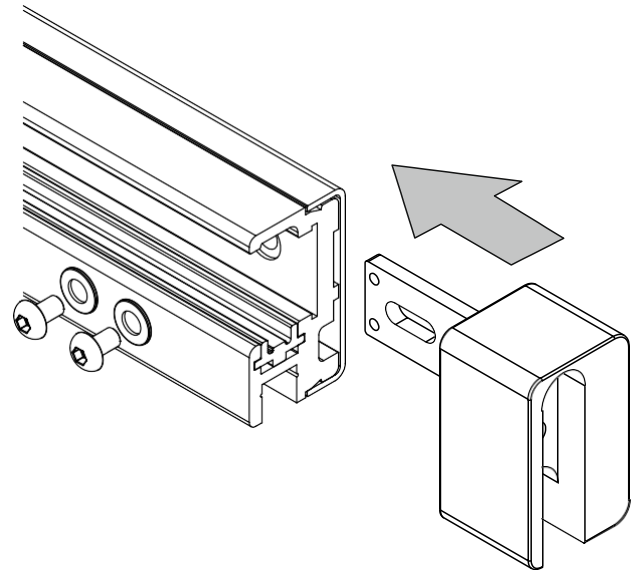

10

Assemble the Wall Bracket to the panel end of the Rail using 2 pan head screws and washers. Do not tighten yet.

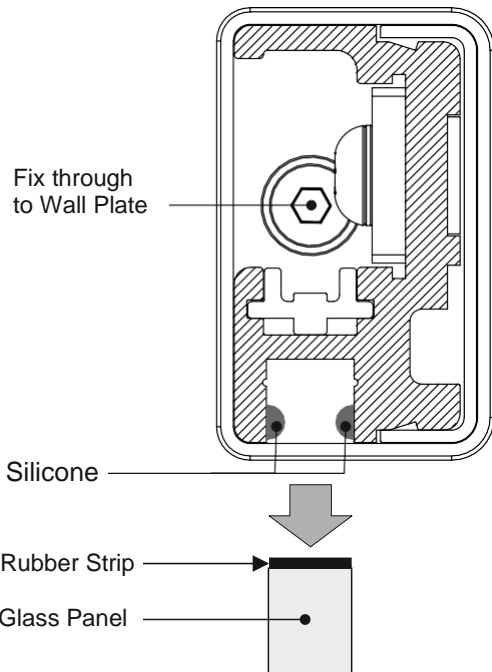

11

Lay rubber strip along the top of the fixed panel, lift the Rail assembly in to position and check that it is level and that the wall brackets can be adjusted to the alcove width.

Remove the rail, apply beads of silicone to the inside of the glass recess, replace and attach to the Wall Plates using the socket head screws and washers. Tighten the screws on the Wall Brackets.

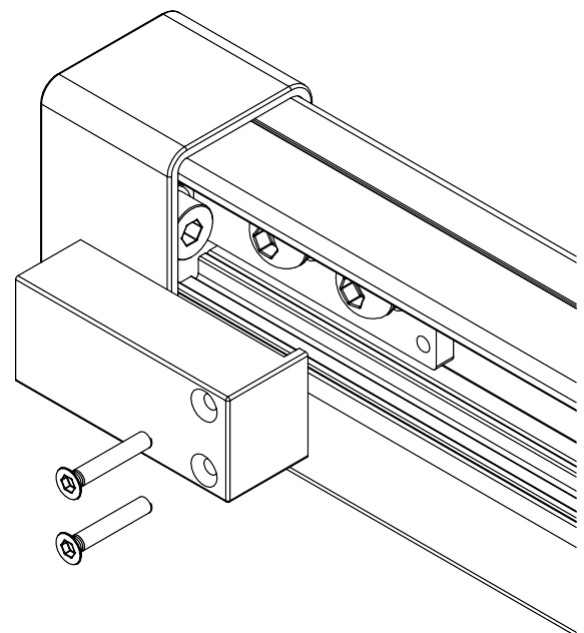

12

With the Rail secured, fit the Cover Blocks at both ends of the Rail.

If the unit is less than 1320mm wide, fit the plain Cover Block at the Door end of the Rail and then refer to Step 13.



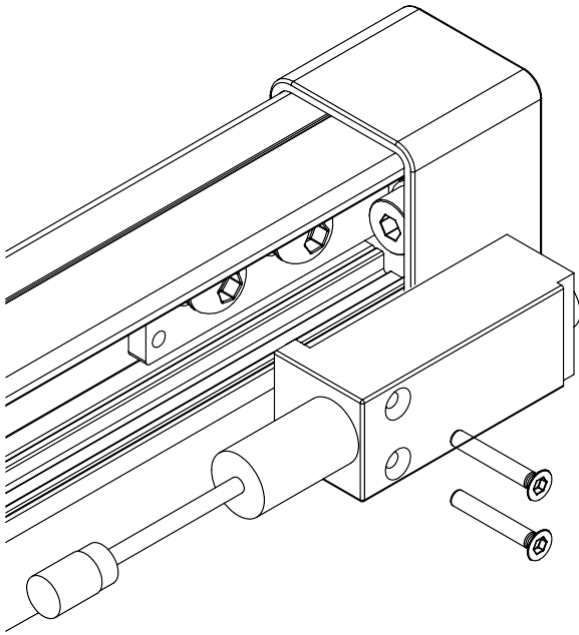

**13** **FOR UNITS LESS THAN 1300mm WIDE ONLY**  
 Fit the Cover Block incorporating the Soft Close cylinder at the Panel end of the Rail.  
 Insert the cylinder in to the block first and then screw the whole assembly into place.

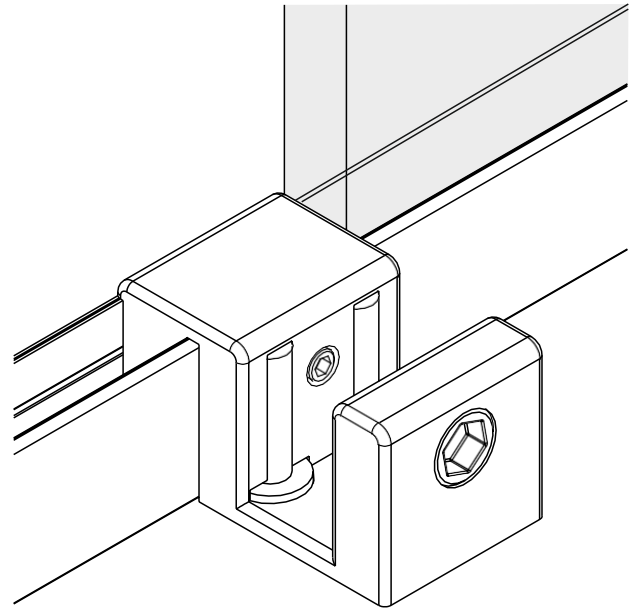

**14** Locate the Door Guide in the Underframe at the end of the Glass In-line Panel.  
 Remove the M10 nylon tipped adjuster screw to access the small grub screw and secure the Guide against the underframe. Replace the adjuster screw.

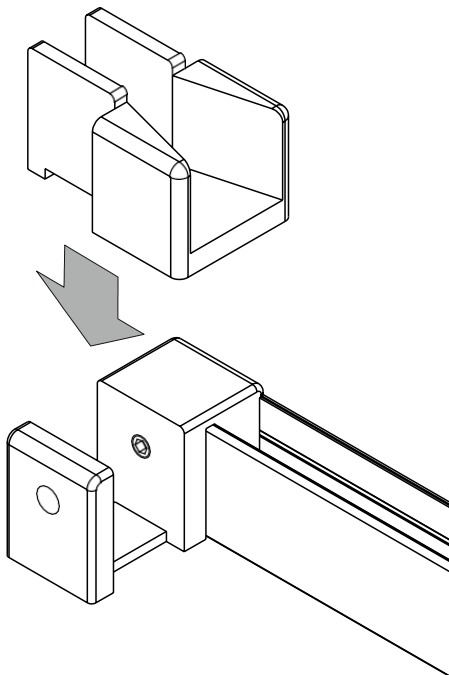

**15** Similarly, fix the metal part of the Shoe assembly into the Underframe at the wall end and tighten the grub screw to secure.  
 Using a smear of silicone on the underside, fix the black plastic shoe in position as shown.

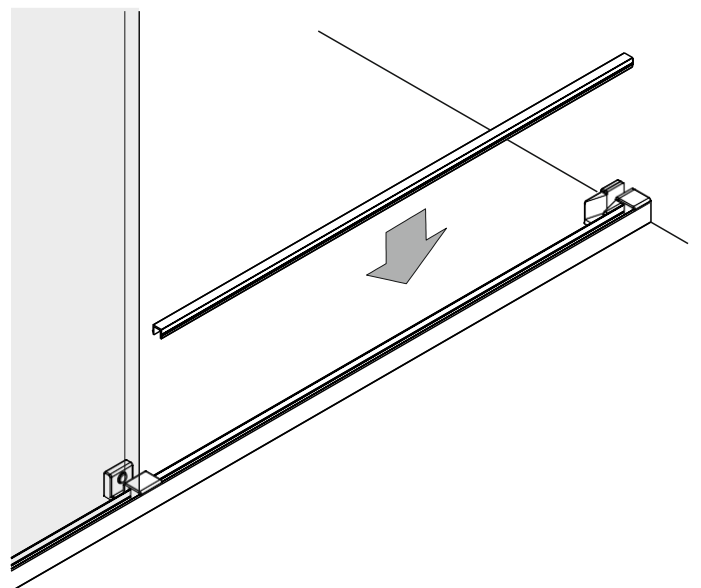

**16** Cut a section of the aluminium Infill profile to fit the Underframe between the Floor Guide and the Shoe assembly. Clip into position.

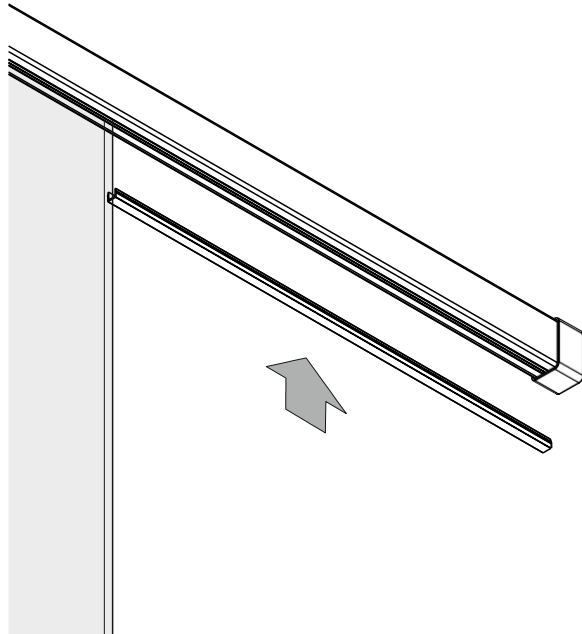

**17** Similarly, fit a length of Rail Infill profile into the Rail above the door opening, between the In-line Panel and the Wall Bracket.

Note that the cut edge of the profile should extend a little into the Return Bracket so that any rough edge is concealed.

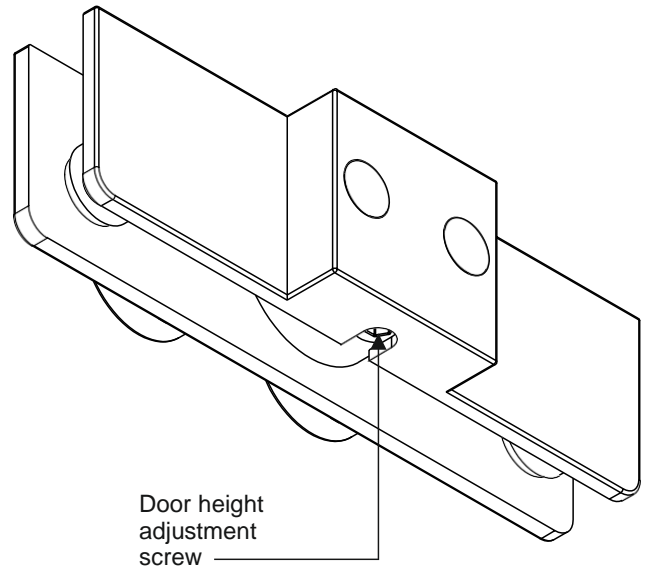

**18** Prepare the Rollerheads for fitting. They incorporate height adjustment screws as shown above. Ensure that these are in an approximate mid way position prior to fitting the doors

Once the door is hanging in position, you can use these height adjustments to ensure that the edge of the door is parallel with the wall against which it closes.

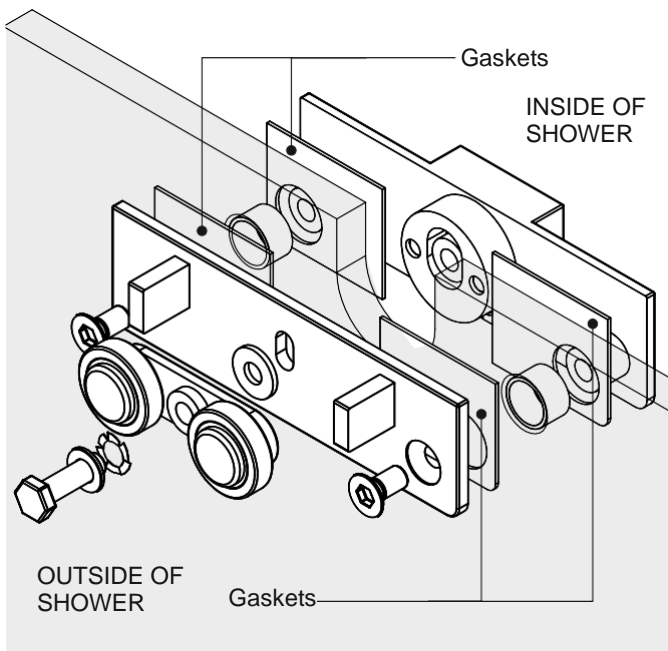

**19** Fit the two Rollerhead assemblies to the top of the door as shown. Check that the rollers are on the correct side of the door.

Take care to ensure that all washers are in the correct positions when reassembling the Rollerheads and ensure that the door has a pvc gasket on both sides of the glass. Fully tighten all screws on

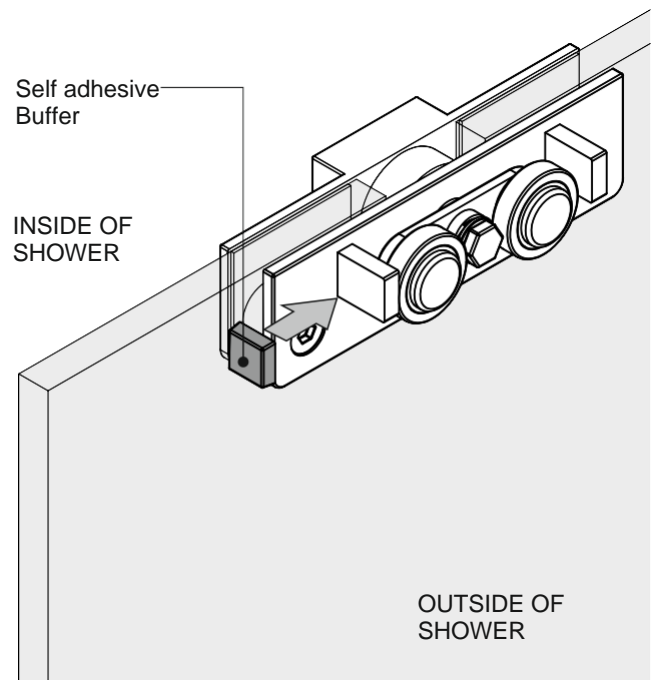

**20** Fit a self adhesive buffer to the tab on the Rollerhead that is closest to the In-line Panel. This is for contact with the soft stop cylinder.

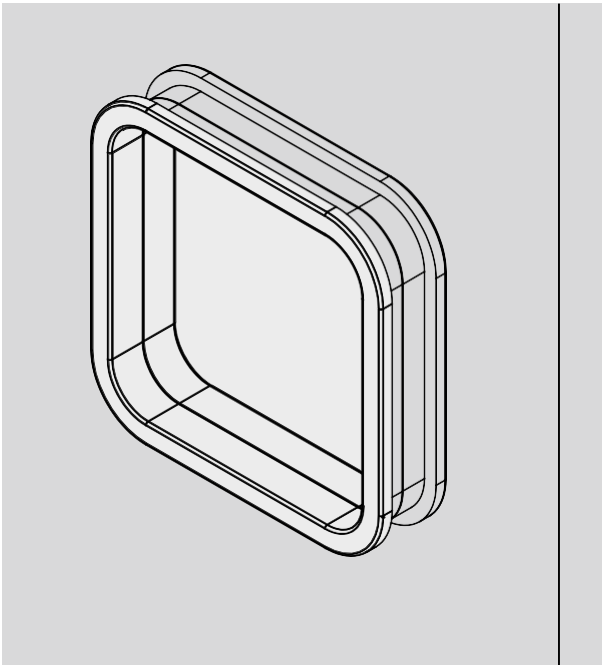

**21** If you have the Finger Pull handle option, the door will be supplied with the handle pre-fitted as shown.

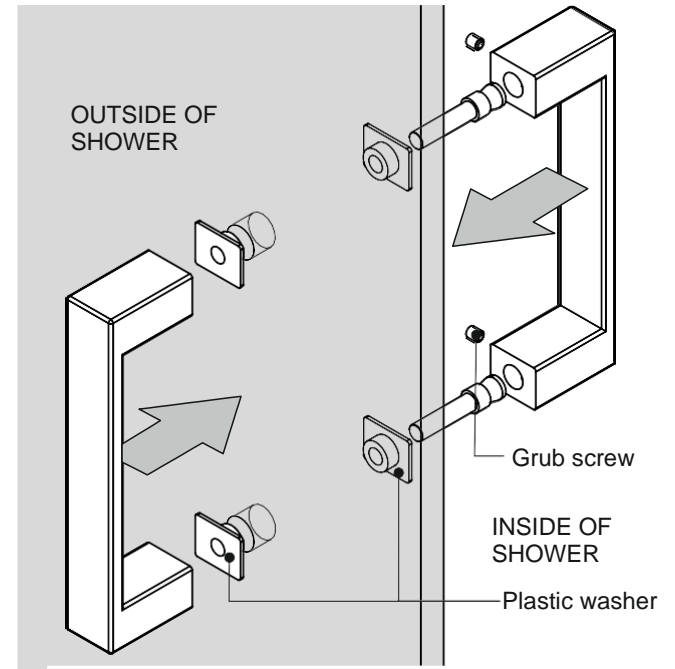

**22** Alternatively, if you have back-to-back handle, fit this to the door as shown, ensuring the black plastic washers are located in the holes on both sides of the glass.

Tighten the grub screws on the inside handle to secure.

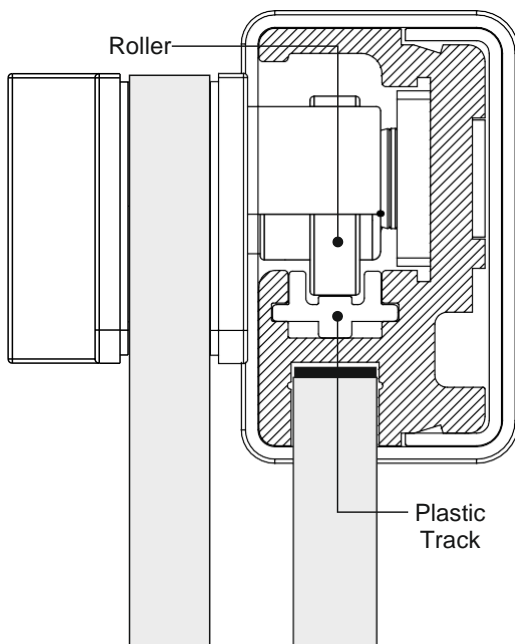

**23** Lift the door into position on the Rail. In smaller enclosures, you may need to lower the door into the Floor Guide before lifting it and locating the rollers on the plastic track.

Check that the door is correctly located and can run

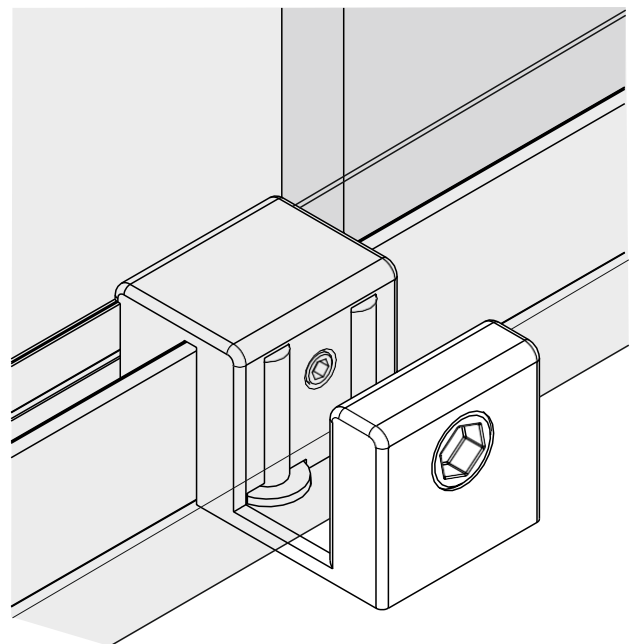

**24** Apply a smear of silicone to the thread of the adjustment screw on the Door Guide and turn it to give slight clearance to the door.

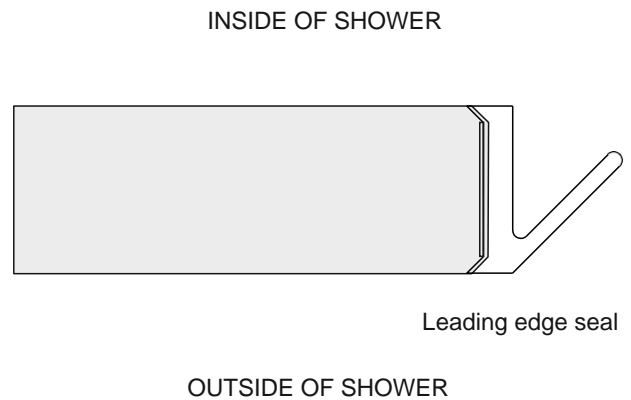
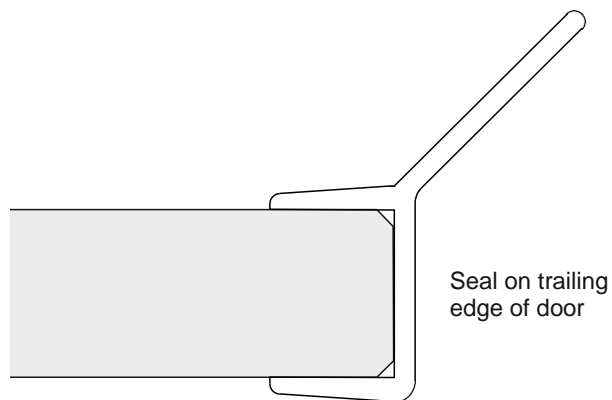

**25**

Push fit the Glass-to-Glass Seal to the trailing edge of the door as shown.

Trim it at the bottom of the door and just below the Rail at the top.

**26**

Prepare the leading edge of the door for fitting the Adhesive Seal. Use the aqueous/alcohol based cleaner supplied to ensure that the glass surface is clean and dry.

Remove the paper backing from the adhesive strip on the back of the seal and fit the seal with even pressure over its full height. Maximum adhesion will be achieved in approximately 72 hours.

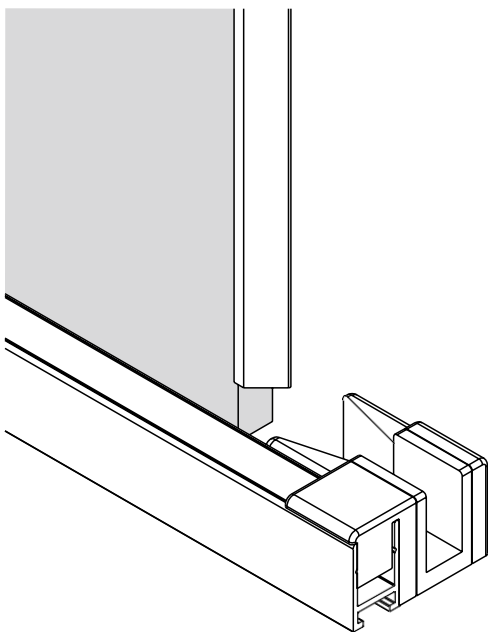

**27**

Trim the adhesive seal level with the top of the door. At the bottom, trim it just above the top of the Shoe as shown above.